

DCMT / Turning

Positive insert / rhomb 55°

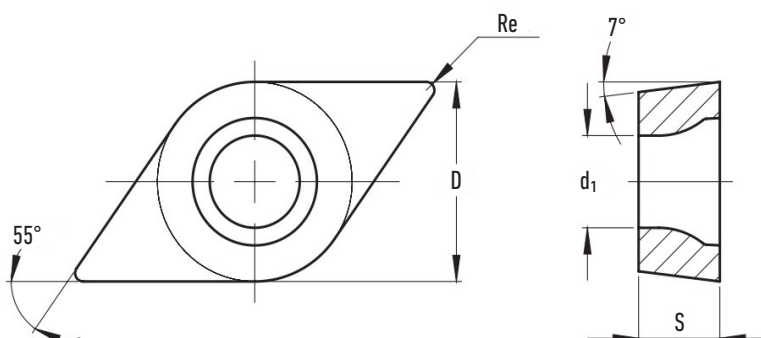
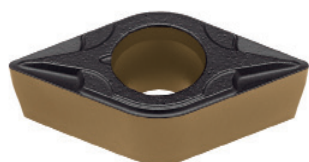

Code	Dimensions					Cutting conditions					
	D	S	Re	d ₁	Ap	Apmin.	Apmax.	Fz	Fzmin.	Fzmax.	
	(mm)					Chip depth (mm)			Feed (mm/t)		
DCMT11T302F	● ○	9,525	3,97	0,20	4,40	0,35	0,08	2,00	0,08	0,04	0,15
DCMT11T304F	● ○	9,525	3,97	0,40	4,40	0,35	0,11	2,00	0,11	0,06	0,23